

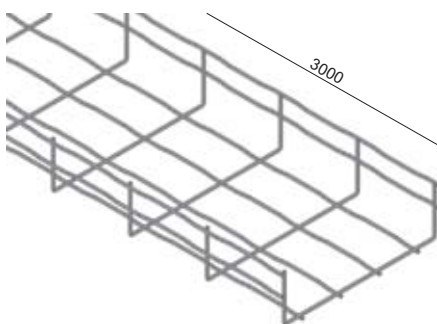

4

WIRE
CABLE
TRAYS





wire cable tray

item number	∅	⊠	‡	BZNCR	BF	BIX
-------------	---	---	---	-------	----	-----

35 - wire cable tray

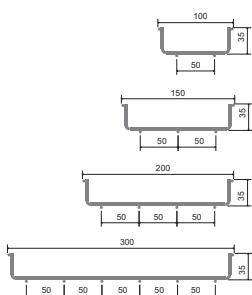

DZ 35X100	4	27	0,55	●	⌚	
DZ 35X150	4	42	0,67	●	⌚	
DZ 35X200	4	58	0,81	●	⌚	
DZ 35X300	4	89	1,27	●	⌚	

60 - wire cable tray



DZ 60X60	4	23	0,55	●	⌚	
INOXDZ 60X60	4	23	0,66			⌚
DZ 60X100	4	47	0,77	●	⌚	
INOXDZ 60X100	4	47	0,96			⌚
DZ 60X150	4	75	0,82	●	⌚	
INOXDZ 60X150	4	75	1,02			⌚
DZ 60X200	4	102	1,06	●	⌚	
INOXDZ 60X200	4	102	1,32			⌚
DZ 60X300	4	157	1,57	●	⌚	
INOXDZ 60X300	4	157	1,69			⌚
DZ 60X400	4	212	1,90	●	⌚	
DZ 60X500	4	267	2,46	●	⌚	
DZ 60X600	4	322	2,83	●	⌚	

110 - wire cable tray

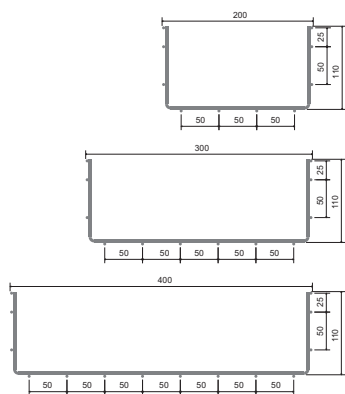

DZ 110X200	4	193	1,57		⌚	⌚
DZ 110X300	4	297	1,90		⌚	⌚
DZ 110X400	4	401	2,46		⌚	⌚

The standard length of the wire cable tray is 3 m.

Screen: 50 x 100 mm (not valid for DZ 60X60, INOXDZ 60X60).

Wire cable trays are joined using the coupling DZS/B (page 4). Trays with side height of 60 and 110 mm can be connected using the quick coupling DZRS/B (page 4) or using the connection reinforcement plate DZPS/B (page 5).

35 - wire cable tray

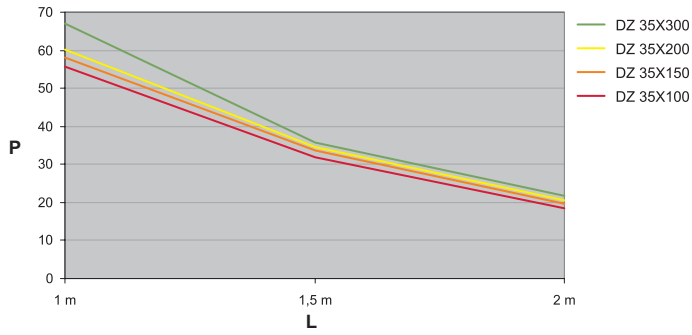

60 - wire cable tray

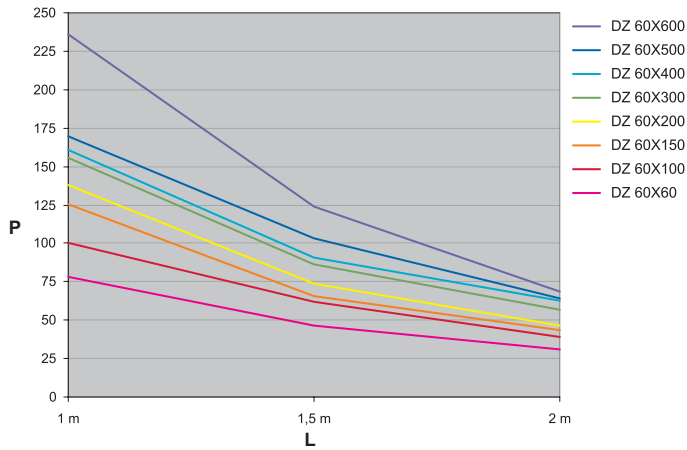

110 - wire cable tray

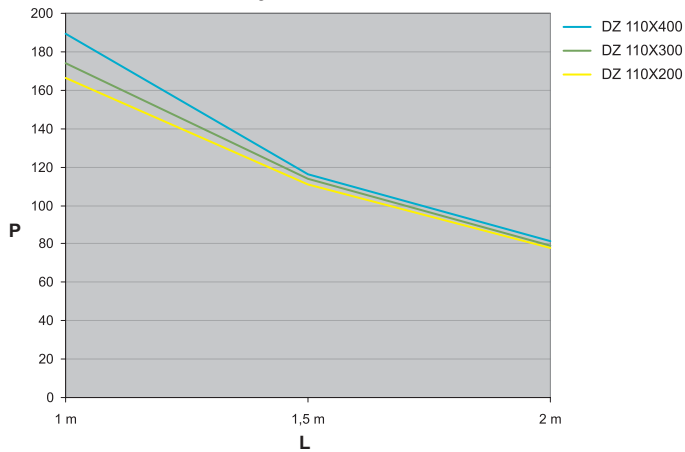

The graphs show the maximum allowed even loading of the trays in relation to the distances of the supports.

L = distance of supports (m)

P = allowed even loading (kg/m)



fastening bolt

item number	‡	ZNCR	BX
DZSU/B	0,02	●	
INOXDZSU/B	0,02		⊕



coupling

item number	‡	ZNCR	F	BX
DZS/B	0,03	●	⊕	
INOXDZS/B	0,03			⊕

The special design of the bolt head enables quick and reliable connection of the trays with all heights of sides.

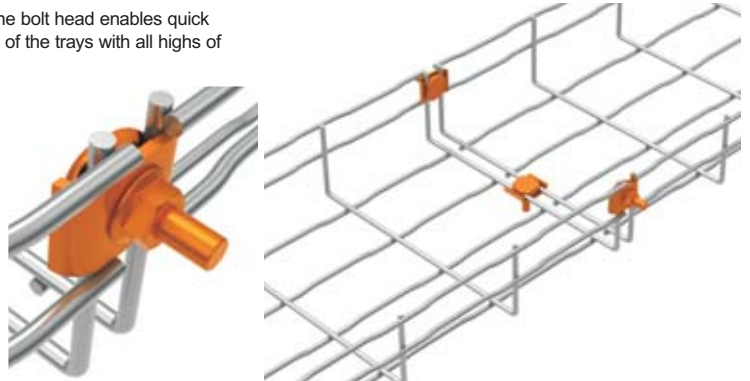

quick coupling

item number	‡	ZNCR	F
DZRS/B	0,03	●	⊕

The quick coupling enables the connecting of the trays with a side height of 60 and 110 mm without using bolts. For the formation of fix connection there is necessary to decline the fixative studs by the anchor.

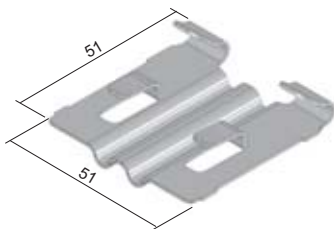
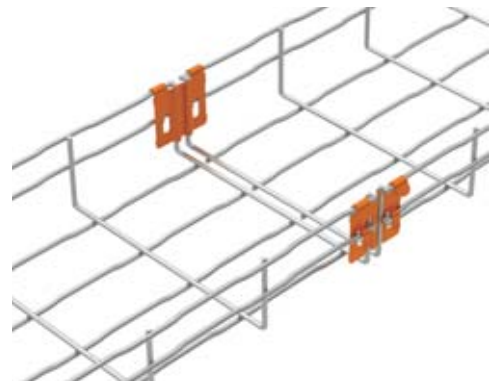

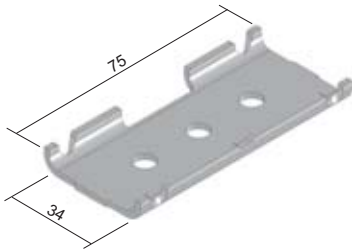

connection reinforcement plate

item number	‡	ZNCR	F	BX
DZSP/B	0,06	●	⌚	
INOXDZSP/B	0,06			⌚

The connection reinforcement plate for a more solid connection of trays. The connection is done using the bolt DZSU/B, which has to be ordered separately. The reinforcement plate is designed for the connecting of wire trays with a side height of 60 and 110 mm.

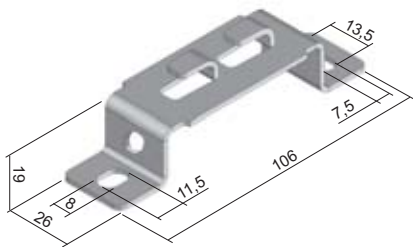
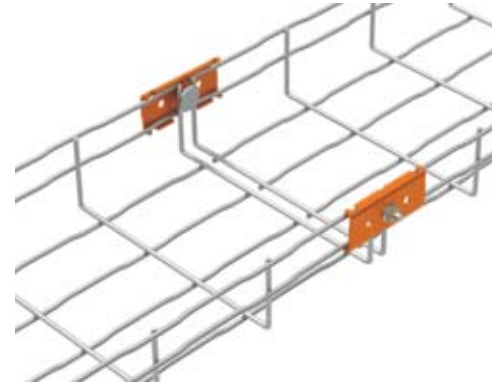

hanger

item number	‡	ZNCR	F	BX
DZZ/B	0,05	●	⌚	
INOXDZZ/B	0,05			⌚

The hanger can be used for the fastening of the wire tray to a wall or for hanging from the ceiling together with a threaded rod \varnothing 8 mm. The hanging by means of 2 threaded bars from the ceiling is intended for the trays of the side height of 60 and 110 mm and of the width of max. 200 mm. The fixation to the wall there is possible just for Trays of DZ 60X60 and DZ 60X100.

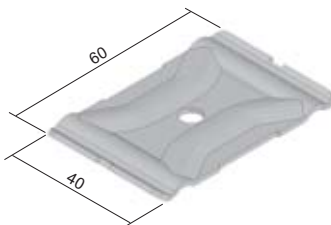
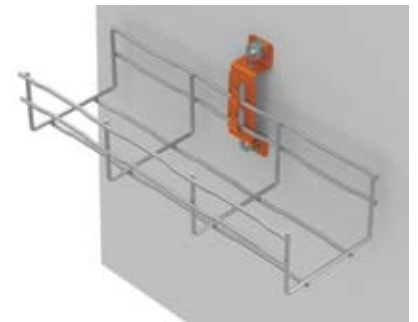

central hanger

item number	‡	ZNCR	F	BX
DZCZ/B	0,03	●	⌚	
INOXDZCZ/B	0,03			⌚

The central hanger is designated for the hanging of the wire tray from the ceiling. For the hanging it is necessary to use two central hanger pieces and the threaded rod \varnothing 8 mm. The hanger is not intended for hanging of the trays of DZ 60X60 and DZ 35X150.

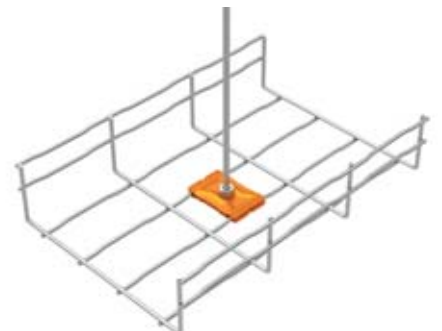

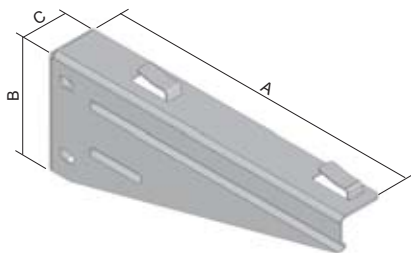

wall bracket

item number	A	B	C	‡	S	F	BX
DZDS 100/B	150	85	36	0,25	●	⊕	
INOXDZDS 100/B	150	86	34	0,24			⊕
DZDS 150/B	200	85	36	0,26	●	⊕	
INOXDZDS 150/B	200	86	34	0,30			⊕
DZDS 200/B	250	85	36	0,38	●	⊕	
INOXDZDS 200/B	250	86	34	0,38			⊕
DZDS 300/B	350	85	36	0,66	●	⊕	
INOXDZDS 300/B	350	86	34	0,49			⊕
DZDS 400/B	450	85	36	0,80	●	⊕	
DZDS 500/B	550	122	36	1,01	⊕	⊕	
DZDS 600/B	650	122	36	1,11	⊕	⊕	

Quick and reliable fixation of the wire tray to the bracket is secured by bending in the fastening tabs.

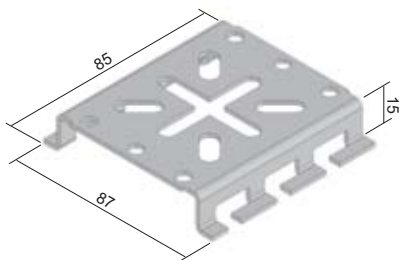
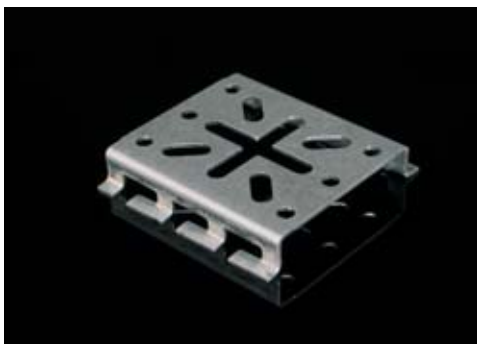
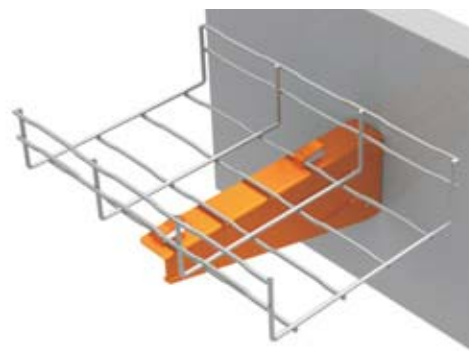

mounting plate

item number	‡	ZNCR	F	BX
DZMD/B	0,08	●	⊕	
INOXDZMD/B	0,08			⊕

Mounting plate serves to the assembling of electroinstallation boxes. It is fixed to the side plate of wire cable tray of side plate height of 60 and 110 mm. Mounting plate there is possible to fix to the outer side of the bottom of all trays, except the trays of DZ 60X60 and INOXDZ 60X60

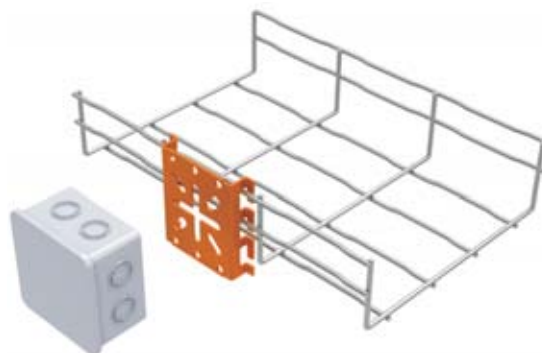



threaded rod

item number	Ø	tolerable bearing resistance*	ZNCR	IX
ZT 8	M 8	4060	●	-
INOXZT 8	M 8	4060	-	⌚

The standard length of the threaded rod is 2 m.
* calm load (N)



hexagon nut

item number	ZNCR	IX
M 8	●	-
INOXM 8	-	⌚



anchor

item number	A	B	C	D	E	thread	‡	PO	ZNCR
KPO 6X50	6	50	35	5	45	M6	0,01	●	-
KPO 6X70	6	70	35	10	70	M6	0,02	●	-
KPO 8X77	8	77	45	10	75	M8	0,03	●	-
KPO 8X97	8	97	45	30	95	M8	0,04	●	-
KPO 10X95	10	95	60	10	90	M10	0,06	●	-
KPO 10X115	10	115	60	30	110	M10	0,08	●	-
KPO 12X120	12	120	70	10	115	M12	0,10	●	-
KPO 12X150*	12	150	70	30	145	M12	0,13	●	-
KKZ 6	8	25	-	-	-	M6	0,01	-	●
KKZ 8	10	30	-	-	-	M8	0,01	-	●
KKZ 10	12	40	-	-	-	M10	0,02	-	●
KKZ 12	15	50	-	-	-	M12	0,05	-	⌚

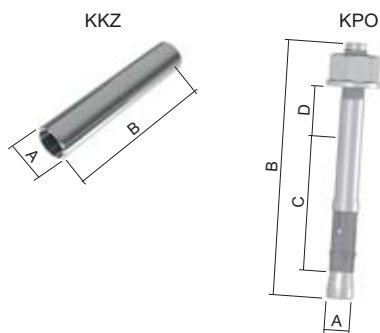

C - anchor depth
D - maximum thickness of the material being attached
E - minimum depth of the drilled hole
Anchors serve for the attaching of construction elements to the base material (concrete, stone).
The knock in anchors KKZ serve for the direct attachment of the threaded rods.
* until the sell-out of stocks



bolt cutter

item number	‡	
DZDN	0,75	●

The cutter has jaws with an offset cut. It is suitable to cut the wires on the trays as close as possible to the crossing.



zinc paint / spray

item number	‡	
WEICON 375 (paint)	0,50	●
GZS (spray)	0,45	●

Anticorrosive protection to be intended for service of defective and damaged places on galvanized surface. Lay on the color by paintbrush, stipple technology.

construction



CUTTING THE WIRE

It is possible to change the shape of the wire tray path according to your requirements. We recommend to use professional wire cutters with an offset cut for the cutting of the tray wire screen (see the drawing below). It is recommend to perform the cutting of the wire as close as possible to the crossing of the wire, to prevent damage to the tables.

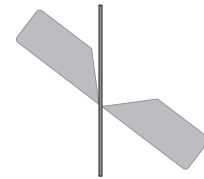
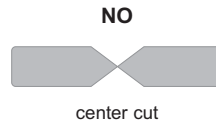
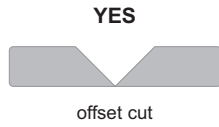

placing of the cutting jaws

BEND

To make the bend, areas must be cut out from the bottom and the side of the wire tray. The connecting wire must not be cut from the outer side. The sides of the wire tray are then bent into a 90° bend. The inner sides are connected using the coupling DZS/B, the second coupling is used to connect the tray bottoms.

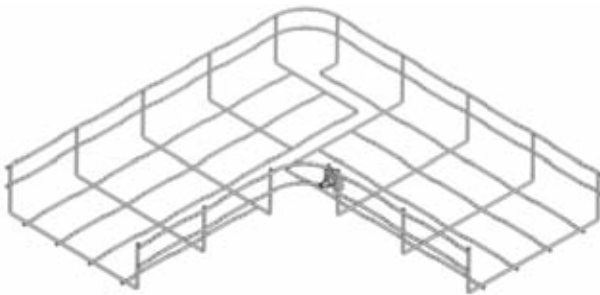

tray width	amount of couplings DZS/B	cutting out of areas	assembly
100	2		
150	2		
200	2		
300	2		
400	2		
500	2		
600	2		

construction

T-PIECE

The T-piece is made out of two pieces of wire trays. Two zones of the "turning" tray are cut off from the bottom, this applies for all tray widths. The sides are cut off from the "continual" tray, the amount of zones depends on the width of the "turning" tray and it is stated in the table. The bottoms and the sides of the trays are connected using the coupling DZS/B.

It is also possible to make the T-piece from various tray widths.

tray width	amount of couplings DZS/B	amount of zones (sides) for removal
100	4	2
150	4	3
200	4	4
300	4	5
400	4	6
500	4	7
600	4	8

amount of cut out zones is stated in the table

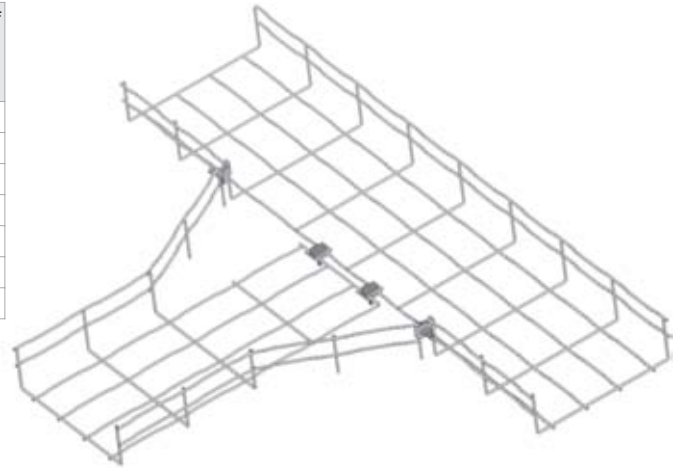
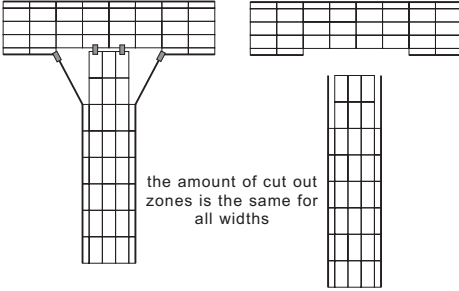
**CROSS-OVER**

The creating of a crossover is basically the creating of two T-pieces. Two zones of the two "turning" trays side are cut off from the bottom, this applies for all tray widths. The sides are cut off from the "continual" tray on both sides, the amount of zones depends on the width of the tray being connected and it is stated in the table. The bottoms and the sides of the trays are connected using the coupling DZS/B.

It is also possible to make the Cross over from various tray widths.

tray width	amount of couplings DZS/B	amount of zones (sides) for removal
100	8	2 + 2
150	8	3 + 3
200	8	4 + 4
300	8	5 + 5
400	8	6 + 6
500	8	7 + 7
600	8	8 + 8

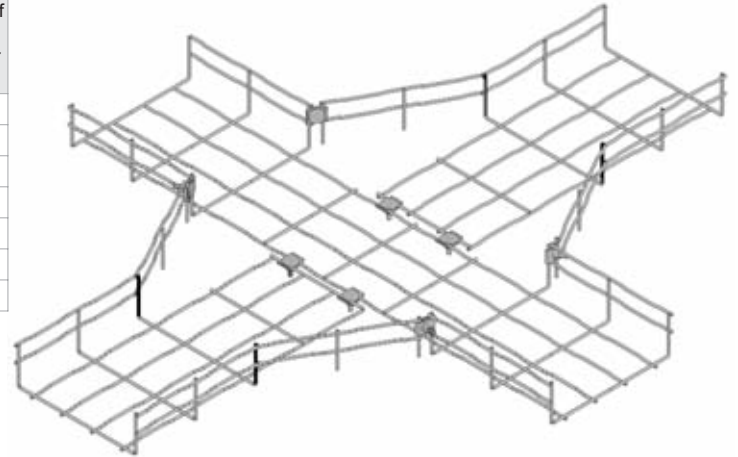
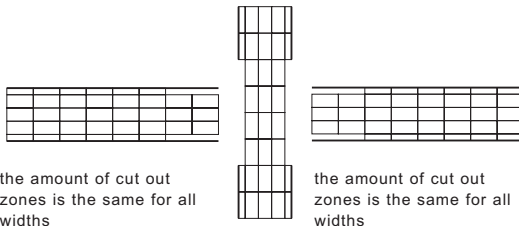
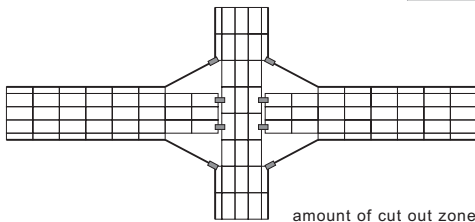

construction

VARYING LEVELS

Any change in the horizontal level can be achieved by cutting off the corresponding zone and bending the wire tray in this area until the required shape is achieved.

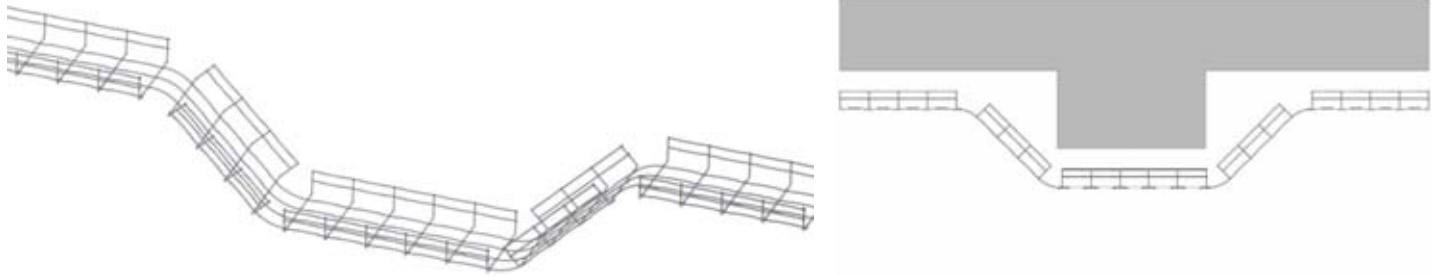

REDUCTIONS

Wire cable trays can be narrowed, so they can be connected to a narrower piece. In order to reach the required result, all of the combinations are based on several basic principles:

- cut out the necessary zones from the bottom and the sides
- bend the side to the required width
- connect the ends using 3 pcs of DZS/B

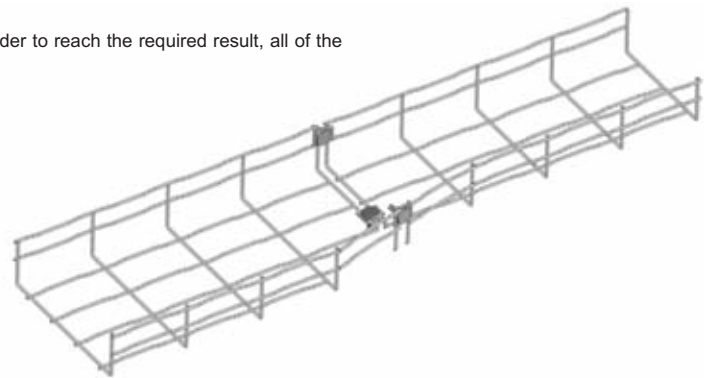

inner usable cross - section of the channel

Type number	cm ²	utilization 50% (cross- section cm ²)	CYKY	CYKY	CYKY	CYKY	CYKY	CYKY	CYKY	CYKY	CYKY	CYKY	CYKY	CYKY	CYKY	CYKY	CYKY	CYKY
			3x1,5	5x1,5	3x2,5	5x2,5	3x4	5x4	5x6	5x10	5x16	5x25	4x35	4x50	3x70+50	3x95+70	3x120+95	3x240+120
			Ø 8,6	Ø 10,1	Ø 9,5	Ø 11,2	Ø 11,2	Ø 13,8	Ø 15,1	Ø 18	Ø 20,4	Ø 26,1	Ø 24,8	Ø 31,3	Ø 33,6	Ø 39,3	Ø 43	Ø 56,4
DZ 35X100	35	17,5	24	17	19	14	14	9	8	5	4	3	3	2	2	0	0	0
DZ 35X300	52,5	26,3	35	26	29	21	21	14	12	8	6	4	4	3	2	0	0	0
DZ 35X200	70	35,0	47	34	39	28	28	18	15	11	8	5	6	4	3	0	0	0
DZ 35X300	105	52,5	71	51	58	42	42	28	23	16	13	8	9	5	4	0	0	0
DZ 60X60	45	22,5	24	18	20	14	14	9	8	6	4	3	3	2	2	1	1	0
DZ 60X100	60	30,0	41	29	33	24	24	16	13	9	7	4	5	3	3	1	1	1
DZ 60X150	90	45,0	61	44	50	36	36	24	20	14	11	7	7	5	4	2	2	2
DZ 60X200	120	60,0	81	59	66	48	48	32	26	19	14	9	10	6	5	4	3	2
DZ 60X300	180	90,0	122	88	100	72	72	47	39	28	22	13	15	9	8	6	5	3
DZ 60X400	240	120,0	162	118	133	96	96	63	53	37	29	18	20	12	11	8	6	4
DZ 60X500	300	150,0	203	147	166	120	120	79	66	46	36	22	24	15	13	10	8	5
DZ 60X600	360	180,0	243	176	199	143	143	95	79	56	43	26	29	18	16	12	10	6
DZ 110X200	220	110,0	149	108	122	88	88	58	48	34	26	16	18	11	10	7	6	3
DZ 110X300	330	165,0	223	162	183	132	132	87	72	51	40	24	27	17	15	11	9	5
DZ 110X400	440	220,0	297	216	244	175	175	116	96	68	53	32	36	22	19	14	12	7

The values state the number of cables with the tray at 50% full. Orientation diameters of the cables CYKY. The values are mathematically calculated. The limit values (small tray x big cable or contrariwise) it is necessary to consider combination of the tray and diameter of the cable and used them with reference to technical conditions.